

REV	ECN No.	DESCRIPTION	DESIGN	DATE
A0		Release	吴丹平	2015.07.07

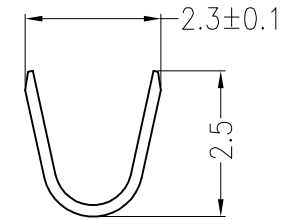

A-A

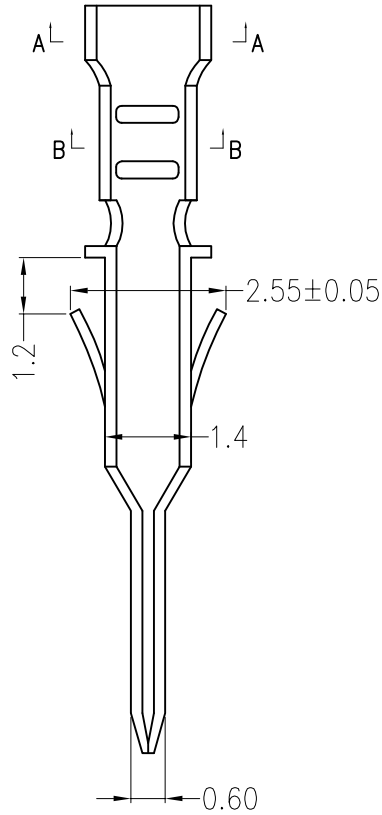
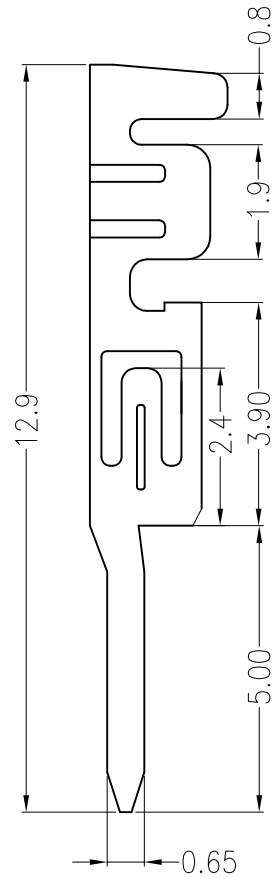
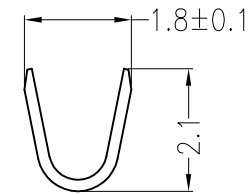

B-B

Ordering Information & Specification:

Part No	Wire Range	Insulation O.D.	Material	Finish	Qty/Reel
C3001RT-PA	AWG #22~#28	1.0~1.90mm	Phosphor bronze	Sn-plated	

東莞市高迪電子有限公司 DONG GUAN GAO DI ELECTRONICS CO., LTD			TITLE: C3001RT	
X.±0.5	X.±5'	USE:	CUSTOMER	
.X±0.3	.X±2'	APPD:	邵敬和	
.XX±0.25	.XX±1'	CHKD:	田峰	
--	--	DR:	蒋建银	
UNITS: mm		SCALE	1 : 1	SHEET
				1 / 1

REV	DESCRIPTION	DESIGN	DATE
A0	Release	蒋建银	2018.01.15

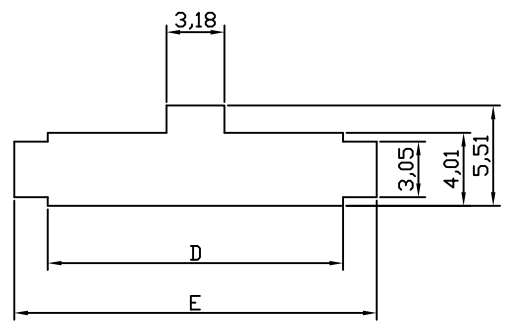
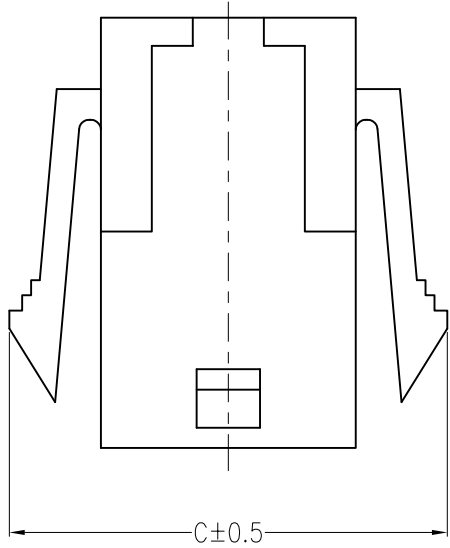
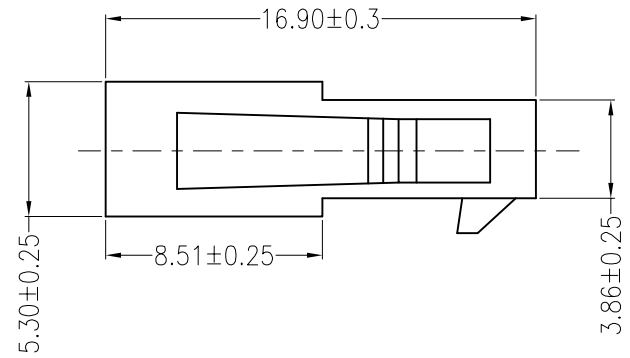
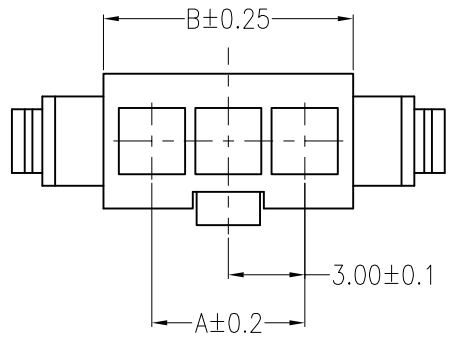

MOUNTING MEASUREMENT

Circuits	Dimensions (mm)				
	A	B	C	D	E
02	3.0	6.80	14.20	7.21	10.90
03	6.0	9.80	17.20	10.21	13.89
04	9.0	12.80	20.20	13.21	16.89
05	12.0	15.80	23.20	16.21	19.89
06	15.0	18.80	26.20	19.21	22.88
07	18.0	21.80	29.20	22.20	25.88
08	21.0	24.80	32.20	25.20	28.88
09	24.0	27.80	35.20	28.20	31.88
10	27.0	30.80	38.20	31.21	34.87
11	30.0	33.80	41.20	34.21	37.87
12	33.0	36.80	44.20	37.22	40.87

主要技术参数 Main Specifications

线数 (Poles): 02 to 24
 接触电阻 (Contact resistance): $\leq 20m\Omega$
 绝缘电阻 (Insulation resistance): $\geq 1000M\Omega$
 额定电压 (Rated voltage): 250V AC DC
 额定电流 (Rated current): 5.0A AC DC
 耐电压 (Withstand Voltage): 1000V AC/minute
 温度范围 (Temperature Range): $-25^{\circ}C \sim +85^{\circ}C$

ORDER INFORMATION:

C3001R--A5K-P**

PART No. PACKAGING:
 No. OF CIRCUITS: P=PE
 02~07 PLASTIC MATERIAL:
A5K=PA66 (Black)

C				
B				
A	PEDESTAL	1 PCS	PA66	COLOR:BLACK
ITEM	COMPONENT	Q'TY	MATERIAL	FINISH
东莞市高迪电子有限公司 DONG GUAN GAO DI ELECTRONICS CO., LTD				TITLE: - 3.00mmPITCH Housing
X.±0.5	X.±5'	USE:	PART NO.: C3001R-**-A5K-P	
.X±0.3	.X±2'	CUSTOMER		
.XX±0.25	.XX±1'	APPD: 邵敬和	DWG NO.: GCCP-0607	
--	--	CHKD: 田峰		
		DR: 蒋建银	SCALE	SHEET
	UNITS: mm		1 : 1	1 / 1

REV	DESCRIPTION	DESIGN	DATE
A0	Release	蒋建银	2018.01.15

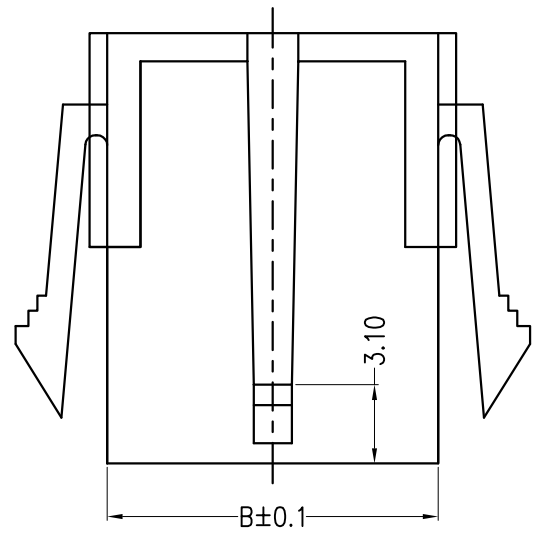
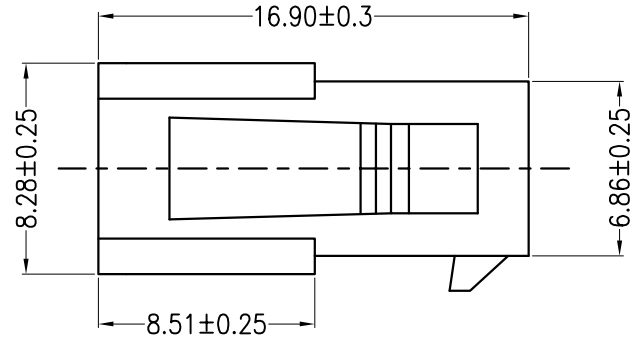
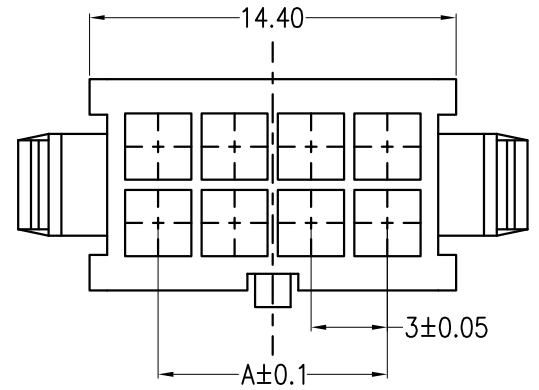

主要技术参数 Main Specifications

线 数 (Poles): 02 to 24
 接触电阻 (Contact resistance): $\leq 20m\Omega$
 绝缘电阻 (Insulation resistance): $\geq 1000M\Omega$
 额定电压 (Rated voltage): 250V AC DC
 额定电流 (Rated current): 5.0A AC DC
 耐 电 压 (Withstand Voltage): 1000V AC/minute
 温度范围 (Temperature Range): $-25^{\circ}C \sim +85^{\circ}C$

ORDER INFORMATION:

C3001R-*-A5K-P**

PART No.	PACKAGING:
No. OF CIRCUITS:	P=PE
201~212	PLASTIC MATERIAL:
	A5K=PA66 (Black)

Circuits	Dimensions (mm)	
	A	B
02		3.86
04	3.0	6.85
06	6.0	9.85
08	9.0	12.85
10	12.0	15.85
12	15.0	18.85
14	18.0	21.85
16	21.0	24.85
18	24.0	27.85
20	27.0	30.85
22	30.0	33.85
24	33.0	36.85

ITEM	COMPONENT	Q'TY	MATERIAL	FINISH
A	PEDESTAL	1 PCS	PA66	COLOR:BLACK

东莞市高迪电子有限公司
 DONG GUAN GAO DI ELECTRONICS CO., LTD

X.±0.5	X.±5'	USE: CUSTOMER
.X±0.3	.X±2'	
.XX±0.25	.XX±1'	APPD: 邵敬和
--	--	CHKD: 田峰
	UNITS: mm	DR: 蒋建银

TITLE: -
3.00mmPITCH Housing

PART NO.:
C3001R-**-A5K-P

DWG NO.:
GCCP-0607

SCALE 1 : 1	SHEET 1 / 1
----------------	----------------